

UNITED STATES COURT OF APPEALS August 25, 2017

TENTH CIRCUIT

Elisabeth A. Shumaker  
Clerk of Court

---

HANNA AINAHHAS; BARBARA  
AINAHHAS,

Plaintiffs - Appellants,

v.

ROBERT BOSCH TOOL  
CORPORATION; SKIL TOOLS,

Defendants - Appellees,

and

CPO COMMERCE, INC.,

Defendant.

No. 16-6163  
(D.C. No. 5:13-CV-00178-D)  
(W.D. Okla.)

---

**ORDER AND JUDGMENT\***

---

Before **TYMKOVICH**, Chief Judge, **BRISCOE** and **MURPHY**, Circuit Judges.

---

---

\* This order and judgment is not binding precedent, except under the doctrines of law of the case, res judicata, and collateral estoppel. It may be cited, however, for its persuasive value consistent with Fed. R. App. P. 32.1 and 10th Cir. R. 32.1.

Plaintiff Hanna AlNahhas<sup>1</sup> was injured when a rotating component of his Skil Orbit Sander, Model No. 7490, fractured and the ensuing fragment struck his right eye. Defendant Robert Bosch Tool Corporation (Bosch) designed and manufactured that sander.<sup>2</sup> Mr. AlNahhas appeals from the district court's grant of summary judgment to Bosch, specifically challenging the disposition of his Oklahoma state law claims of strict products liability based on design defect and failure to warn. Exercising jurisdiction pursuant to 28 U.S.C. § 1291, we reverse on both claims, and remand for further proceedings.

---

<sup>1</sup> Barbara AlNahhas, Mr. AlNahhas's spouse, is the other plaintiff in this action. Her sole claim of injury is for loss of consortium under Oklahoma law. See Williams v. Hook, 804 P.2d 1131, 1137 & n.33 (Okla. 1990). Bosch inquired at length as to *her* claim at *Mr.* AlNahhas's deposition. We do not know whether Mrs. AlNahhas was deposed.

In any event, Bosch did not specifically address or even identify Mrs. AlNahhas's loss of consortium claim in its motion for summary judgment, even as it contended that it was entitled to summary judgment on "all of" the AlNahhases's "claims." *Aplt. App.* at 69. The district court likewise did not discuss Mrs. AlNahhas's claim in its order granting summary judgment to Bosch, or in its judgment. But we are confident that, on these facts, Mrs. AlNahhas's claim is included in the judgment, which is therefore final, obviating any concern regarding our jurisdiction. See 28 U.S.C. § 1291. However, we do not need to discuss Mrs. AlNahhas or her claim further to resolve this appeal.

<sup>2</sup> The complaint also named as defendants "CPO Commerce, Inc." and "Skil Tools." Id. at 16. The district court dismissed CPO Commerce from this action without prejudice because service was not perfected on time. See Fed. R. Civ. P. 4(m). That ruling is not challenged on appeal. It also is undisputed that "Skil Tools" is "a division of" Bosch, i.e., "a brand name, not a legal entity." *Aplt. App.* at 11. We therefore affirm the district court's grant of summary judgment to "Skil Tools."

I.

Mr. AlNahhas is a self-taught recreational woodworker with twenty-five years of experience. Between five and six years prior to the accident, Mr. AlNahhas purchased the motorized, handheld random-orbit sander at issue for use in his woodworking projects. That particular sander is capable of sanding wood, polishing metal, and shaping other materials. Specifically, the sander achieves the intended effect by oscillating the housing-and-friction-ring “assembly” at its base 12,000 times per minute, which rotates the replaceable foam-and-fiberglass-composite “disc” installed on the assembly, in turn spinning the disposable piece of “sandpaper” attached to the disc.<sup>3</sup> The design of the disc and whether or not certain warnings were adequate to account for the disc’s actions are the focal points of this appeal.

This case arose as a result of Mr. AlNahhas’s injuries on April 22, 2012. He was preparing to use the sander on a new project. And because Mr. AlNahhas had not used the sander in some months, perhaps even years, he decided to determine first whether the sander was operational.

---

<sup>3</sup> The components that we refer to as the assembly, the disc, and the sandpaper are among those integral to the operation of the sander. Unfortunately, each of these items is referred to inconsistently throughout the record and in the parties’ briefs, and it is apparent that in several instances a term previously employed to refer to one component subsequently is used to refer to a different component, even in the same document. To avoid confusion, we have altered and bracketed material quoted from the record as appropriate. The appendix includes images of the sander, the warning label affixed to it, the assembly, and the disc, as well as a graphic depicting how the sandpaper attaches.

As we will discuss in more detail below, Mr. AlNahas understood the warning label affixed to the sander and the owner's manual to instruct that he should always wear eye protection while using the sander, to shield his eyes from dust and other particulates created by the sanding process.<sup>4</sup> However, in Mr. AlNahas's view, at that time he was merely testing whether the sander was operational. For example, he had not attached sandpaper to the disc, and he was not applying the disc to a surface. Mr. AlNahas therefore did not don protective eyewear when he conducted this test.

Commensurate with his routine maintenance practices—and as the manual instructs—Mr. AlNahas plugged in the sander and pressed the power switch to determine whether the sander would turn on. The motor engaged, and the assembly and disc began to oscillate. Two seconds later, however, the disc fractured, hurling foam and fiberglass. Unfortunately, one or more of the disc fragments struck Mr. AlNahas's eye, resulting in partial loss of vision. This and Mr. AlNahas's other injuries have not been fully corrected despite several surgical interventions and ongoing medical treatment.

Following the accident, Mr. AlNahas sued Bosch in Oklahoma state court on claims of negligence, gross negligence, and strict products liability based on design defect and failure to warn, all based on Oklahoma law. Bosch removed the case to federal court. See 28 U.S.C. § 1332(a). Mr. AlNahas thereafter voluntarily dismissed his claim for gross negligence. Discovery ensued, punctuated by administrative stays as Mr. AlNahas underwent additional medical procedures.

---

<sup>4</sup> Mr. AlNahas admits he read the warning label on the sander and the manual.

After the close of discovery, Bosch moved for summary judgment on Mr. AlNahas's three remaining claims. The district court granted that motion in full. In particular, the district court reached its conclusion, in part, in reliance on the opinions presented in the affidavit and report of Bosch's expert witness, Thomas R. Siwek, a Bosch employee. The district court also based its decision to grant summary judgment, in part, on the opinions expressed by Mr. AlNahas's expert witness, Robert N. Anderson, Ph.D., in a report and deposition testimony. Mr. AlNahas timely appealed, challenging only the disposition of the design defect and failure to warn claims.

## II.

We begin by detailing the applicable legal standard. We then take up a preliminary question Bosch has raised about what evidence we should consider here: i.e., whether to exclude Dr. Anderson's testimony and his report, obtained during discovery, and an affidavit he authored after the close of discovery. Once we have established what record is before us, we will discuss what facts are supported by that record, a point of serious contention between the parties. Finally, we apply the facts to the substantive elements of Mr. AlNahas's design defect and failure to warn claims. We conclude, after that review, that there are genuine disputes of material fact which require us to reverse the district court's grant of summary judgment and remand.

### A. Legal Standard

This court reviews a district court's grant of summary judgment de novo, applying the same legal standard as the district court applied. Universal Underwriters Ins. Co. v. Winton, 818 F.3d 1103, 1105 (10th Cir. 2016). In doing so, "[w]e view the facts in the light most favorable to the nonmovant and draw all reasonable inferences in the nonmovant's favor." Jones v. Norton, 809 F.3d 564, 573 (10th Cir. 2015). "Summary judgment is proper 'if the movant shows that there is no genuine dispute as to any material fact and the movant is entitled to judgment as a matter of law.'" Universal Underwriters, 818 F.3d at 1105 (quoting Fed. R. Civ. P. 56(a)).

"An issue is genuine if there is sufficient evidence on each side so that a rational trier of fact could resolve the issue either way. An issue of fact is material if under the substantive law it is essential to the proper disposition of the claim." Savant Homes, Inc. v. Collins, 809 F.3d 1133, 1137 (10th Cir. 2016) (quotation marks and citation omitted).

"The movant bears the initial burden of making a prima facie demonstration of the absence of a genuine issue of material fact and entitlement to judgment as a matter of law." Id. (quotation marks and citation omitted).

"A movant who does not bear the burden of persuasion at trial may satisfy this burden by pointing out to the court a lack of evidence on an essential element of the nonmovant's claim." Id. (quotation marks and citation omitted). "If the movant meets this initial burden, the burden then shifts to the nonmovant to set forth specific facts from which a rational trier of fact could find for the nonmovant." Id. (quotation marks and

citation omitted). “These facts must establish, at a minimum, an inference of the presence of each element essential to the case.” Id. at 1137–38 (quotation marks and citation omitted).

Finally, to “determine whether genuine issues of material fact make a jury trial necessary, a court necessarily may consider only the evidence that would be available to the jury.” Brown v. Perez, 835 F.3d 1223, 1232 (10th Cir. 2016), as amended on reh’g (Nov. 8, 2016) (quotation marks and citation omitted). “This does not mean that summary judgment evidence must be submitted in a form that would be admissible at trial.” Id. (quotation marks and citation omitted). “Parties may, for example, submit affidavits . . . despite the fact that affidavits are often inadmissible at trial as hearsay, on the theory that the evidence may ultimately be presented at trial in an admissible form.” Id. (quotation marks and citation omitted). “Nonetheless, the content or substance of the evidence must be admissible.” Id. (quotation marks and citation omitted). “The requirement is that the party submitting the evidence show that it will be possible to put the information, the substance or content of the evidence, into an admissible form.” Id. at 1233 (quotation marks and citation omitted).

#### B. What evidence to consider

Bosch filed two motions in the district court with respect to Dr. Anderson. The first was to exclude from consideration his deposition testimony and expert witness report. Oddly, however, Bosch also *submitted* that evidence to the district court in

support of its motion for summary judgment, and directly relied on it. Bosch's second motion was to strike a separate affidavit filed with Mr. AlNahas's response to Bosch's motion for summary judgment. This affidavit was authored by Dr. Anderson after the close of discovery.

The district court denied both the motion to exclude and the motion to strike as moot in its order granting Bosch's motion for summary judgment. It also relied on Dr. Anderson's report and testimony in granting summary judgment to Bosch, though not on the affidavit. Dr. Anderson's evidence is in the appellate appendix, and the parties rely on it here. Bosch also filed a (largely duplicative) supplemental appendix containing its moot motions. We first turn to Dr. Anderson's affidavit, and then address his testimony and report.

*1. The untimely affidavit*

We first note that the district court did not rely on Dr. Anderson's affidavit. We take this to mean that the district court thought this evidence was untimely and not admissible under any exception, and Mr. AlNahas has offered none. See Fed. R. Civ. P. 37(c)(1); Brown, 835 F.3d at 1232. Like the district court, therefore, we will not consider Dr. Anderson's untimely affidavit.

*2. The expert witness report and deposition testimony*

Dr. Anderson's report and deposition testimony are another matter. Bosch devotes much of its brief to casting aspersions on Dr. Anderson's supposed testimony and



opinions. But propping up and then knocking down a straw-man version of the expert's evidence and opinions does not advance Bosch's position or, moreover, aid our review.

For example, Bosch contends that Dr. "Anderson acknowledged that [Mr.] AlNahas was not injured by material separation of the type that he hypothesized might occur at the end of the [disc's] useful life." Aple. Br. at 6 (citing Aplt. App. at 155). We do not read Dr. Anderson's testimony to say that. Dr. Anderson testified: "If I've used [the disc] for some period of time, considerable period of time, wore it down, pressed the foam and so forth, then I would expect the type of fracture that I actually saw in this matter." Aplt. App. at 155. Unfortunately, this distortion of the evidence by Bosch is not an isolated incident.

As things stood before oral argument, we might have ignored these distortions with respect to Dr. Anderson's evidence and simply limited ourselves to his actual testimony and opinions. But in the final seconds of its presentation, Bosch "ask[ed]" that "on de novo review" we determine "that Dr. Anderson's testimony should not be considered." Oral Arg. at 29:57–30:14. We surmise from this very tardy request that Bosch is now asking us (a) to consider and grant its moot motions—i.e., to exclude this evidence in the first instance on appeal, despite the district court's reliance on it; and, therefore, (b) to affirm, if nothing else, on some alternative basis in its absence.

Bosch appears to be alluding to our discretion to "affirm a lower court's ruling on any grounds adequately supported by the record, even grounds not relied upon by the

district court.” Elwell v. Byers, 699 F.3d 1208, 1213 (10th Cir. 2012). But Bosch’s invocation of this principle is off base in these circumstances for two reasons.

First, Bosch waived the argument by failing to make this request in its brief. See United States v. De Vaughn, 694 F.3d 1141, 1154–55 (10th Cir. 2012) (holding “arguments inadequately briefed . . . are waived”). We refuse to excuse this waiver.

Second, in any event, we have no discretion to do what Bosch asks of us, based either on its request, or *sua sponte*. Specifically, “the exercise of” our discretion to affirm on an alternative basis “is guided by,” *inter alia*, “whether, in light of factual findings to which we defer or uncontested facts, our decision would involve only questions of law,” as is, for example, our determination that the untimely affidavit is inadmissible. Brown, 835 F.3d at 1236 (quotation marks and citation omitted). With respect to Dr. Anderson’s testimony and report, we cannot usurp the district court’s gatekeeping role by determining in the first instance on appeal whether—as a factual matter—an expert witness’s evidence or opinions are insufficient and, on *that* basis, inadmissible as a matter of law under Federal Rule of Evidence 702. See Etherton v. Owners Ins. Co., 829 F.3d 1209, 1216 (10th Cir. 2016) (explaining that our review is “for abuse of discretion,” and that we afford “substantial deference” to the district court as to the fact-finding aspects of this inquiry); United States v. Medina-Copete, 757 F.3d 1092, 1100 (10th Cir. 2014) (discussing this “gatekeeping role”). Like the district court, therefore, we consider Dr. Anderson’s testimony and report in reviewing whether summary judgment is appropriate.

C. Genuine disputes of fact

We now discuss certain facts supported by the evidence on this record, and whether there are genuine disputes about those facts, before we apply them to the substantive merits of Mr. AlNahhas's claims (i.e., before we discuss materiality). See Collins, 809 F.3d at 1137. We must "view the facts in the light most favorable to" Mr. AlNahhas "and draw all reasonable inferences in" his "favor." Jones, 809 F.3d at 573.

We typically discuss together whether a purported disagreement over a fact constitutes a genuine dispute and whether that fact is material to the claims at issue. E.g., Collins, 809 F.3d at 1137. Doing so often, though not always, allows us to begin and end with whichever inquiry is easier. Here, however, the primary tension between the parties is whether certain purportedly material "facts" are genuinely in dispute. We proceed then in an attempt to set the factual record straight in certain respects before we proceed to determine which undisputed and genuinely disputed facts actually in evidence are material to Mr. AlNahhas's claims.

1. *Mr. AlNahhas's practices as alleged by Bosch*

Bosch states that Mr. AlNahhas had a "practice of using his tools to the point of failure instead of maintaining them and replacing wear items." Aple. Br. at 9. It repeats variants of this statement, including this: "[Mr.] AlNahhas chose not to maintain his tools or replace wear items or components. Instead, he used his tools until a component failed. When failure occurred, he would discard the tool and purchase a new one. [Aplt. App. at

84.] The sander was no exception.” Id. at 3.

Tellingly, however, in no instance does Bosch quote Mr. AlNahas’s testimony allegedly to this effect. In fact, it does not even include “citations to the authorities and parts of the record on which [it] relies” for this purported admission. Fed. R. App. P. 28(a)(8)(A); see Fed. R. App. P. 28(b) (directing that “[t]he appellee’s brief must conform to,” *inter alia*, Rule 28(a)(8)). At oral argument, Bosch took this claim a step further. It informed us that at his deposition, Mr. AlNahas “point blank stated, ‘I never maintain my tools. I use my tools [un]til failure.’” Oral Arg. at 16:30–36.

When we review Mr. AlNahas’s testimony on this point, it differs from Bosch’s description.

a. Maintaining the sander

It is far from clear what Bosch means by “maintaining” the sander. Aple. Br. at 9. In particular, the “Maintenance” section of the manual discusses various types of “service” that “should” be or is “recommended” to be “performed by a Skil Factory Service Center or Authorized Skil Service Station,” not “unauthorized personnel.” Aplt. App. at 119. The manual does not indicate the disc requires professional maintenance.

b. Inspecting the sander

We surmise, however, that when Bosch claims that Mr. AlNahas failed to “maintain the sander,” Aple. Br. at 2, it is not using that term as defined in its own manual. Bosch instead appears to be referring colloquially to whether Mr. AlNahas

“inspected” the sander’s components. Aplt. App. at 90.

Yet nowhere in Mr. AlNahas’s testimony does he admit to having failed to perform any of the inspections described in scattered sections of the manual. In fact, Mr. AlNahas testified that he performed numerous inspections on the sander. E.g., id. at 86 (“That’s when I decided to plug it in and make sure it was working. I looked at the dust collector and it was clean. I pulled it off, looked at it[,] and put it back in.”); id. at 89 (responding to whether he “inspect[s]” his “tools routinely to see if any of the parts of the tools are worn or damaged” by describing the inspections he performed, including observing “the bottom of the disc,” which “looked normal to” him). Mr. AlNahas thus “[c]heck[ed] for” and observed no “breakage of parts,” an inspection which, by Bosch’s own definition, he completed “before” he was “using” the sander. Id. at 113.

Bosch suggests that these inspections or Mr. AlNahas’s response to his observations must have been inadequate because the disc was “visibly worn” and, in the view of its expert, “worn down to its plastic substructure.” Aple. Br. at 18. But the manual specifically instructs an owner to inspect for the “breakage of parts,” and does not mention worn parts. Aplt. App. at 113. Moreover, it is debatable which types of “damaged” parts the manual indicates must be addressed “before using” the sander—i.e., whether this includes all forms of damage (e.g., visible wear), or only the specific types of damage listed in that paragraph, which directs the owner’s attention to “breakage,” not visible wear. Id. This is a genuine dispute of fact, and it is far from undisputed proof that

Mr. AlNahas chose not to maintain” the sander. Aple. Br. at 3.

Mr. AlNahas also testified that “[i]t just makes sense to make sure” an “electrical tool[]” is “working before you buy supplies for it.” Aplt. App. at 87. The last such “check” he performed was to “make sure the motor still work[ed].” Id. at 89. Bosch claims this test was not a “foreseeable use of its product” because “Bosch told users to only turn on the sander when the [disc] is in contact with the surface to be sanded . . . .” Aple. Br. at 21. This is yet another mischaracterization of the record.

Actually, the “Tool Tips” for “sanding” include this instruction: “DO NOT start the tool *and bring it up to speed* before applying to *the work*; swirl marks will result in either case.” Aplt. App. at 117 (emphasis added). Whatever it means to bring this bimodal sander “up to speed,” there is no evidence that Mr. AlNahas did so when he conducted his power-on test, a test during which Mr. AlNahas was not “sanding” and no “work” was at hand. Id. The “result[s]” of Mr. AlNahas’s test, made away from any “work,” could not have resulted in “swirl marks,” the risk of which the manual warns. Id.

It is also difficult to see how an owner could comply with the instruction to test whether the disc is “binding” up without activating the sander. Id. at 113. The manual further instructs the owner to “not use” the sander “if” the power “switch does not turn it ‘ON’ or ‘OFF.’” Id. Such a malfunctioning switch is “dangerous,” the manual warns, “and must be repaired.” Id.

Plainly, at least some of the inspections that the manual directs an owner to

perform are not “uses” of the sander. Viewing the facts in the light most favorable to Mr. AlNahhas, we also know that he performed the instructed pre-use inspections of the switch and disc at least once. He began those tests on the day of the accident, but they ended abruptly when the disc fractured and his injury resulted.

These facts regarding Mr. AlNahhas’s maintenance and inspection of the sander are, at minimum, genuinely disputed. It also is impossible to square Mr. AlNahhas’s testimony and the other evidence with Bosch’s repeated claim that it is undisputed he “chose not to maintain” the sander, Aple. Br. at 3, or its even more outlandish claim that he admitted to “never” maintaining his tools. Oral Arg. at 16:30–36.

c. Alleged practice of using tools until they failed

Bosch also devotes significant attention to Mr. AlNahhas’s admission that he never replaced the disc, and to his supposedly related practice of not installing a “replacement part[.]” when a component on one of his tools “wears out.” Aplt. App. at 84. Bosch appears to distort the record in two ways to suggest that this means Mr. AlNahhas admitted to a “practice of using his tools to the point of failure.” Aple. Br. at 9; see generally Fed. R. App. P. 28(a)(8)(A).

First, Bosch argues that Mr. AlNahhas knew that the disc needed to be replaced and yet continued to use the sander. Aple. Br. at 3. The record does not support this claim. The manual states in pertinent part: “After considerable service the [disc] surface will become worn, *and* the [disc] must be replaced *when it no longer offers a firm grip*. If

you are experiencing premature wear[-]out of the [disc] *facing*, decrease the amount of pressure you are applying during operation of the tool.” Aplt. App. at 117 (emphasis added).

Bosch’s claims regarding the amount of wear to the disc and the degree of pressure Mr. AlNahas supposedly applied to it are conclusive of nothing. There is *no* evidence that the disc on Mr. AlNahas’s sander could no longer firmly grip sandpaper. The only tangentially relevant evidence on this point is Mr. AlNahas’s testimony that immediately preceding the accident, the disc “looked fine to” him. *Id.* at 91. The record belies Bosch’s claim that Mr. AlNahas must have known that the disc needed to be replaced. This is a genuine dispute of material fact.

Second, Bosch contends that Mr. AlNahas’s supposed practice of using his other tools until they fail demonstrates his behavior could not have been foreseen by Bosch and further proves that he disregards warnings, such that Bosch is not liable for the ensuing injury. But according to his actual testimony, Mr. AlNahas has no such practice. In particular, Mr. AlNahas testified: “I never buy replacement parts for [my] tools. I throw them away if they go out. . . . I replace a tool. I don’t fix a tool. They are too cheap to spend money fixing them. It’s easier to throw them away and get another one.” *Id.* at 84. Bosch appears to be suggesting that this is direct evidence that Mr. AlNahas puts himself at risk of injury by continuing to use tools with worn-out parts until they fail and injure him.



However, Mr. AlNahas's related testimony clarifies this issue. This colloquy between Mr. AlNahas and Bosch's attorney is one pertinent example:

Q. So if *anything wears out* on your tool, you just throw it away? You don't replace it?

A. I replace a tool. I don't fix a tool. They are too cheap to spend money fixing them. It's easier to throw them away and get another one.

Id. (emphasis added) (bolding removed). Mr. AlNahas further explained: "I don't replace parts on any tools. *If it comes to a point where I need[] to replace a part* on [a] tool, I'd rather throw it." Id. at 89 (emphasis added). Mr. AlNahas was asked directly whether this practice of purchasing cheap replacement tools instead of conducting repairs means that he uses his "tools to the point of failure." Id. at 93. He responded: "*I don't know* if I use them to the point of failure. I just know [that] when a tool that I had failed, it was always without causing damage. It was the tool going out without pieces coming off it." Id. (emphasis added).

Plainly Mr. AlNahas's practice of replacing the entire tool whenever "any[]" component "wears out" is *not* an admission that he continues to use his tools *after* their components wear out, id. at 84, or, as Bosch describes it, "until a component fail[s]." Aple. Br. at 25. Mr. AlNahas appears to have instead testified that, for economic reasons, it is his practice to purchase new tools rather than replace worn-out parts by purchasing standalone replacement parts. We are puzzled by Bosch's counterfactual argument on this point. This is, at minimum, a genuine dispute of fact.

## 2. *Pointing the sander*

Bosch also repeatedly states that Mr. AlNahas “turn[ed] the sander on while pointing the disc at his face.” Aple. Br. at 7–8. Bosch provides no record cite to support this statement. There are references in the report of Bosch’s own employee-expert to the alleged location of the sander when Mr. AlNahas was injured, but Mr. Siwek was not present when the accident occurred.

Rather, Mr. AlNahas was asked during his deposition to “show” Bosch’s counsel how he was “holding the sander.” Aplt. App. at 87. His response appears in the transcript as, “(Witness complied).” *Id.* Bosch’s counsel asked, “So you were holding the sander at an angle, but not pointing directly down?” *Id.* He responded: “Right.” *Id.*

These vague statements given without any points of reference do *not* support a claim that Mr. AlNahas pointed the disc or the sander at, directly at, or even in the general direction of his face or of his head. Mr. AlNahas certainly did not *testify* or otherwise *admit* to having done so. Continuing that same theme, Bosch argued in its motion for summary judgment that it cannot be held responsible for Mr. AlNahas’s having “turn[ed] on a power tool whose main component is a rotating disc while holding it *at almost eye level* pointed towards [his] face.” *Id.* at 66 (emphasis added). Pressed at oral argument, Bosch’s counsel eventually conceded that there is *no* evidence in our record of these claimed facts, directly contradicting Bosch’s averments in its sworn statements to both the district court and this court. *See, e.g., id.* at 54 (stating that “Bosch’s summary judgment [motion] is based on, and *supported by*, the following

*evidence*” (emphasis added)).

Bosch offers us a seemingly plausible explanation for *some* of its actions. According to Bosch, were we to review the *video* record of Mr. AlNahhas’s deposition, we would observe him demonstrating that he held the sander pointing toward his face and almost at eye level, as Bosch’s pleadings state. But as Bosch knows, the video was not submitted to the district court, and it also is not in the record presented to this court. See Fed. R. App. P. 30(b); 10th Cir. R. 30.2(A)(1). Regardless of what the video shows, or not, Bosch’s claims about the evidence in *this* record are unsupported. See 10th Cir. R. 10.3(B), (D)(2), (4).

### 3. “Using” the sander

The parties dispute whether Mr. AlNahhas was “using” the sander when he inspected it, which relates to whether the warnings in the manual required him to don protective eyewear. Aplt. Br. at 27; Aple. Br. at 11. We disagree with the district court’s conclusion that this is not a genuine dispute of material fact. We also reject Bosch’s efforts to avoid this issue by framing an owner’s every contact with the sander as using the sander.

Our review of the record confirms it is a genuine dispute of material fact whether Mr. AlNahhas was using the sander when he tested it. In particular, Mr. AlNahhas testified that because he “wasn’t sanding anything with” the sander during his test, he “didn’t think [he] was using it.” Aplt. App. at 87. At the summary judgment stage, we

are not permitted to disbelieve Mr. AlNahhas's testimony, and we must view it in the light most favorable to him. See Jones, 809 F.3d at 573. The district court correctly recognized that Mr. AlNahhas's testimony raises a factual dispute about whether he was using the sander.

The district court erred, however, in dismissing this factual issue without any reference to the record that would explain why it is not a *genuine* dispute. See Collins, 809 F.3d at 1137. "An issue is genuine if there is sufficient evidence on each side so that a rational trier of fact could resolve the issue either way." Id. Here, in addition to Mr. AlNahhas's testimony, the manual states that "before using" the sander, the owner should test for, *inter alia*, "binding of moving parts," and that the owner should "not use" the sander if the power "switch does not turn it 'ON' or 'OFF.'" Aplt. App. at 113.

The instructions to test the sander in this manner before using it establish, at minimum, that whether Mr. AlNahhas was using the sander when he conducted his test is a genuine dispute of material fact. This in turn implicates the separate but related genuine dispute of material fact regarding the scope of the eye protection warnings. Do the warnings to wear eye protection apply only when one is using the sander, or also when one is testing the sander, which would include Mr. AlNahhas's specific activities at the time of the accident? With these facts in mind, we now turn to the merits.

#### D. The merits of Mr. AlNahhas's claims

Mr. AlNahhas has two remaining claims under Oklahoma law: (1) strict products

liability based on an alleged defect in the design of the sander; and (2) strict products liability based on Bosch's failure to warn him of the risk that the disc could fracture and injure him. We first set out the relevant law and then address each claim in turn.

1. *State law applies*

Mr. AlNahas's claims arise under the substantive law of the State of Oklahoma. "When jurisdiction is based on the parties' diverse citizenship, a federal court must assess state law claims based on the substantive law of the state." Etherton, 829 F.3d at 1223. "Our objective when interpreting and applying state substantive law is to reach the same result that would be reached in state court." Id. (quotation marks and citation omitted). "If the state's highest court has" opined on the issue, "we defer to that decision." Id. (quotation marks and citation omitted). "If the state's highest court has not" done so, "we instead predict how that court would rule." Id. (quotation marks and citation omitted); see Schrock v. Wyeth, Inc., 727 F.3d 1273, 1280 (10th Cir. 2013) (discussing other sources of law to which we may refer, where appropriate). "The decisions of lower state courts, while persuasive, are not dispositive." Etherton, 829 F.3d at 1223 (quotation marks and citation omitted). Specifically, "[t]he decision of an intermediate appellate state court is a datum for ascertaining state law which is not to be disregarded by a federal court unless it is convinced by other persuasive data that the highest court of the state would decide otherwise." Id. at 1223–24 (quotation marks and citation omitted).

The parties discuss a number of cases applying the substantive products liability

law of other states. Though the district court cited and applied several Oklahoma cases, it also discussed—in some instances, relied exclusively on—authorities applying other states’ laws to determine several of the elements of Mr. AlNahhas’s claims.

We reject that analytical approach in these circumstances. Richter v. Limax Int’l, Inc., 45 F.3d 1464, 1468 (10th Cir. 1995) (“Appellate review of a district court’s determination of state law is *de novo*.” (citing Salve Regina Coll. v. Russell, 499 U.S. 225, 231 (1991))). These claims have a well-established pedigree in Oklahoma law. We do not think any aspect of this case suggests Oklahoma’s courts would depart from their settled principles, or that it requires us to predict how they would answer any novel question. See Schrock, 727 F.3d at 1283–84. Consequently, we will rely exclusively on Oklahoma authorities establishing the state’s products liability law and on our own precedents predictively applying it. Etherton, 829 F.3d at 1223–24; see Klaxon Co. v. Stentor Elec. Mfg. Co., 313 U.S. 487, 497 (1941) (“[T]he proper function of [a] federal court is to ascertain what the state law is, not what it ought to be.”).

## 2. *Oklahoma products liability law*

Under Oklahoma law, “[a] manufacturer does not undertake to provide a product that will never wear out,” nor does Oklahoma law “require a manufacturer to build a fail-safe product.” Stuckey v. Young Expl. Co., 586 P.2d 726, 731 (Okla. 1978). Further, “the fact that someone was injured while using the product does not establish that the product was unreasonably dangerous when put to its intended use. It is not enough to

merely contend that a defect existed, show that an accident occurred, and assume the two are necessarily related.” Beverly v. Wal-Mart Stores, Inc., 3 P.3d 163, 167 (Okla. Civ. App. 2000) (quotation marks and citation omitted). Bosch places great emphasis on these concepts, as did the district court. But they are merely obvious background principles.

As in every case, we must address the particulars of Mr. AlNahhas’s claims. More specifically, “Oklahoma, like most states, has adopted a strict liability regime for products that are defectively manufactured or designed.” Braswell v. Cincinnati, Inc., 731 F.3d 1081, 1085 (10th Cir. 2013). “The Oklahoma Supreme Court has identified three elements to a products liability claim: the defect must have (1) caused the injury in question, (2) existed at the time it left the manufacturer’s control, and (3) made the product unreasonably dangerous.” Id. (citing Kirkland v. Gen. Motors Corp., 521 P.2d 1353, 1363 (Okla. 1974)).

“The plaintiff carries the burden of proof on each of these elements.” Dutsch v. Sea Ray Boats, Inc., 845 P.2d 187, 190 (Okla. 1992) (citation omitted).<sup>5</sup> As the district

---

<sup>5</sup> Certain cases discuss whether “the defective product did not cause the injury” as one of the “defenses to this tort,” but nevertheless place the “burden of proof . . . on the plaintiff . . . .” Treadway v. Uniroyal Tire Co., 766 P.2d 938, 941 (Okla. 1988). However, Dutsch and other cases confirm that whether “the product was the cause of the injury” is an “element which must be proven by the plaintiff in a” products liability case. 845 P.2d at 190. Therefore, we have consistently discussed causation as an element rather than an affirmative defense. See, e.g., Braswell, 731 F.3d at 1085. To the extent that certain complex questions of causation trigger burden-shifting tests that might deviate from this general description, the straightforward cause of Mr. AlNahhas’s injury does not implicate them. See, e.g., Johnson v. Ford Motor Co., 45 P.3d 86, 91–92 (Okla. 2002) (discussing the burden-shifting framework applicable to “enhancement” injuries); Lee v. Volkswagen of Am., Inc., 688 P.2d 1283, 1286 (Okla. 1984) (discussing “second impact injuries”).

court remarked, Oklahoma’s courts have described this “burden” as “a large and heavy one.” Kirkland, 521 P.2d at 1364. More specifically, this means that at trial, a plaintiff “must prove their case by a preponderance of evidence on the prima facie issues to avoid a directed verdict.” Lee v. Volkswagen of Am., Inc., 688 P.2d 1283, 1288 (Okla. 1984). A plaintiff can meet this burden with “[c]ircumstantial evidence, coupled with the proper inferences drawn from it,” and “[a]ctual or absolute proof is not required because this type of proof may be within the possession or peculiar knowledge of the defendant.” Id. at 1285–86. Of course, at the summary judgment stage, our inquiry is whether the plaintiff has shown (a) that there are undisputed facts establishing or, at least, genuine disputes of fact over (b) the issues material to each element on which the plaintiff bears the burden of proof. See Universal Underwriters, 818 F.3d at 1105.

In Oklahoma, a “defect can stem from either a dangerous design or an inadequate warning about the product’s dangers.” Braswell, 731 F.3d at 1085. “Because Oklahoma has just one test for whether a product is unreasonably dangerous—the consumer expectations test—most cases treat design defects and inadequate warnings as merely different methods of proof for the same products liability claim.” Id. at 1092 n.3 (collecting cases). The “warnings sufficient to counteract an otherwise dangerous design usually satisfy the manufacturer’s duty to warn” as well. Id.

In this case, the parties have consistently discussed Mr. AlNahhas’s allegations of design defect and failure to warn as if they are two entirely distinct claims. The district



court followed that approach. We will do so as well, without reiterating the analysis of overlapping elements. We conclude by addressing Bosch's apparent assertion of affirmative defenses.

a. Design defect

Mr. AlNahas claims that the sander was defectively designed because "the presence of voids and the mixture of brittle and plastic regions made the . . . disc too weak for the intended use." Aplt. Br. at 27 (citing Aplt. App. at 192). According to Dr. Anderson, Bosch used a "brittle hard material in conjunction with soft foamy material" to create this disc, Aplt. App. at 145, a design that "guaranteed" the "unusual composite" disc was "going to fail." Id. at 152. Specifically, "the stresses on" those materials are "different" during "oscillation" of the disc, "and they are going to tend to want to tear away from one another." Id. at 155. Dr. Anderson opines that this defect in the "manufacturer's molding process was the cause of the failure, and made the disc unreasonably dangerous." Id. at 192.

He testified that if the disc were "new," then "one way" the defect would manifest itself would be that the brittle material would "separate[] from the foam." Id. at 155. If, on the other hand, the owner had "used [the disc] for some . . . considerable period of time" and "wore it down," then Dr. Anderson "would expect the type of fracture that" occurred in Mr. AlNahas's case. Id. Dr. Anderson also examined the disc "for abuse" and "didn't see unusual wear," noting that there was "a lot left" of the disc. Id. at 157.

Additionally, Dr. Anderson contends that the disc “may be a bad design” because it is “capable of failing ballistically”; i.e., Bosch “designed” it “to be in a moving situation” but, “after a period of time, . . . parts can be thrown off” of it. Aplt. Br. at 31 (quoting Aplt. App. at 159). Dr. Anderson suggests that the disc should “fail benignly” instead. Aplt. App. at 159. Mr. AlNahhas contends this “design defect . . . caused the [disc] to fail and send pieces flying into [his] face and eye.” Aplt. Br. at 27.

i. Causation

On a claim of design defect, a plaintiff must prove that the defect was the proximate cause of his injury. See Braswell, 731 F.3d at 1086; Johnson v. Ford Motor Co., 45 P.3d 86, 93 (Okla. 2002). Bosch advances two arguments why Mr. AlNahhas cannot prove causation on this evidence that the fractured disc pieces injured him.

First, Bosch argues that Dr. “Anderson conceded that the sander was appropriate for its purpose when it left Bosch’s control,” Aple. Br. at 6, and that he “acknowledged that [Mr.] AlNahhas was not injured by material separation of the type that he hypothesized might occur at the[] end of the pad’s useful life.” Id. at 7 (citing Aplt. App. at 155); see Aplt. App. at 249–50 (advancing this theory for the first time in its reply brief in support of its motion for summary judgment). The district court did not specifically discuss causation with respect to this claim. But the district court appears to have agreed with Bosch’s view, as it remarked that Mr. AlNahhas does “not contend the sander was defective *per se* when it left the manufacturer,” and stated that “[t]he fact that the [disc]

eventually wore down over time and repeated use is antithetical to a products liability claim.” Aplt. App. at 264–65.

We disagree. Dr. Anderson opined that this defect existed from the time that Bosch designed this disc, which was “guaranteed” to “fail.” Id. at 152; see id. at 224 (denying Bosch’s claim to the contrary); id. at 227 (explaining that Bosch’s claim was asserted “without any reference to the record,” and discussing Dr. Anderson’s testimony “as to the defect in the” disc); id. at 228 (describing this testimony and Dr. Anderson’s report). He also testified that this failure could have occurred even if the disc were “new,” which buttresses the conclusion that this defect existed at the time of design. Id. at 155. In fact, Dr. Anderson testified that the disc on Mr. AlNahhas’s sander experienced the very “type of fracture” that he “would expect” to result from that defect if the disc had been used “for a considerable period of time,” as this disc had been. Id.; see Aplt. Br. at 30–31 (quoting Dr. Anderson’s opinions, including that Bosch’s “molding process was the cause of the failure” and “fracture” of the disc).

Second, Bosch contends that Mr. AlNahhas was injured “because he was not wearing eye protection.” Aple. Br. at 5. Affixed to the sander is a label containing this statement: “!WARNING[.] TO REDUCE THE RISK OF INJURY, USER MUST READ AND UNDERSTAND INSTRUCTION MANUAL, WEAR EYE PROTECTION, USE DUST MASK AND ATTACH DUST BOX.” Aplt. App. at 140. The manual also contains two warnings concerning protective eyewear. The narrower version states:

**“Always wear eye protection and a dust mask for dusty applications and when sanding overhead.** Sanding particles can be absorbed by your eyes and inhaled easily[,] and may cause health complications.” *Id.* at 113. A broader warning states: **“Use safety equipment. Always wear eye protection.** Dust mask, non-skid safety shoes, hard hat, or hearing protection must be used for appropriate conditions.” *Id.* at 112.

Bosch appears to rely on the law in Oklahoma that “[i]f some act of the plaintiff *caused* the injury, rather than the defective product itself, causation is missing, and the plaintiff may not recover.” McMurray v. Deere & Co., 858 F.2d 1436, 1444 (10th Cir. 1988) (quoting Kirkland, 521 P.2d at 1366). Bosch misapprehends the meaning of this rule of causation under Oklahoma products liability law. Under Oklahoma law, the “proximate cause of an injury is the efficient cause, i.e.[,] the agency which produces the effect. It must be that cause which sets in motion the chain of circumstances leading to the injury.” Akin v. Mo. Pac. R. Co., 977 P.2d 1040, 1054 (Okla. 1998). Oklahoma’s courts have explained that, “[g]enerally, the question of proximate cause is one for the jury.” Prince v. B.F. Ascher Co., 90 P.3d 1020, 1029 (Okla. Civ. App. 2004). Bosch has not convinced us otherwise.

In particular, the first aspect of the inquiry into proximate cause is whether “a defect in the defendant’s product was *a* cause of the injury.” Black v. M & W Gear Co., 269 F.3d 1220, 1236 (10th Cir. 2001) (emphasis added); *see* Johnson, 45 P.3d at 93 n.19 (“Direct cause[] means a cause which, in a natural and continuous sequence, produces

injury and without which the injury would not have happened.”). “There may be more than one direct cause of an injury. When an injury is the result of a defect in a product as well as the conduct of another person, *both* the defect and the conduct of the other person are direct causes of the injury . . . .” Johnson, 45 P.3d at 93 n.19 (emphasis added).

According to Dr. Anderson, several aspects of the design of the disc caused it to fracture and to do so in a manner that flung pieces of the disc toward Mr. AlNahhas. If the disc had not fractured, Mr. AlNahhas would not have sustained any injuries. The alleged design defect was one of the direct causes of Mr. AlNahhas’s injuries. See id.

Next, however, “[t]his causal connection may be broken by the occurrence of what is known in Oklahoma jurisprudence as a supervening cause.” Akin, 977 P.2d at 1054. “A supervening cause is a *new, independent and efficient cause of the injury which was neither anticipated nor reasonably foreseeable.*” Braswell, 731 F.3d at 1086 (quoting Akin, 977 P.2d at 1054–55). “A three-prong test is applied to determine whether an intervening event is a supervening cause. It must be: (1) independent from the original . . . act, (2) *adequate in itself to bring about* the relevant injury, and (3) reasonably unforeseeable.” Akin, 977 P.2d at 1055 n.81 (emphasis added) (citations omitted).

Bosch argues that Mr. AlNahhas “would never have been injured if he had simply followed the warnings to always wear eye protection.” Aple. Br. at 12. But it is a genuine dispute of fact whether the warnings as stated on the sander and in the manual actually instructed Mr. AlNahhas to don protective eyewear *during his test*. See

McMurray, 858 F.2d at 1444 (explaining that this inquiry actually involves the affirmative defense of assumption of risk and the issue of a plaintiff's negligence, which is not a defense in products liability cases, both of which are distinct from this issue of proximate cause). Moreover, Bosch does not explain how this is a supervening cause of Mr. AlNahas's injuries, or even acknowledge the requirements to satisfy that legal standard. In any event, if the disc had not fractured, Mr. AlNahas would not have sustained any injury to his eye, regardless of whether he was wearing protective eyewear. Neither the presence nor, especially, the absence of protective eyewear *itself* injured him—he did not poke himself with glasses, for example. Akin, 977 P.2d at 1055 n.81. As a matter of Oklahoma law, Mr. AlNahas's failure to don protective eyewear cannot be a supervening cause of his injuries.

We conclude that there are genuine disputes of material fact about whether Mr. AlNahas's injuries were proximately caused by the alleged defect.

ii. Preexisting defect

The second element that Mr. AlNahas must establish to succeed on his claim of design defect is that the alleged defect in the disc existed at the time it left Bosch's control. Braswell, 731 F.3d at 1085. Among other things, Dr. Anderson opined this is so because the composite design of the disc guaranteed that it would fail, and that it could fail ballistically, as it did in Mr. AlNahas's case. Aplt. App. at 152, 155, 159.

Bosch claims that Dr. “Anderson opine[d] that the sander is defective simply

because a piece of the sanding pad broke off some years after [Mr.] AlNahhas bought the sander.” Aple. Br. at 15. It then responds to its own claimed fact by noting that “a product is not defective merely because it eventually wears out and fails.” Id.

Bosch is “arguing that the lapse of time in and of itself” means no “defect existed in the product when it left” Bosch’s control. Hurd v. Am. Hoist & Derrick Co., 734 F.2d 495, 501 (10th Cir. 1984). “Although under Oklahoma law a lapse of time between sale and the accident may frequently prevent an inference that the product was defective when sold, it does not preclude a finding of defectiveness at the time of sale.” Id. (citing Hawkins v. Larrance Tank Corp., 555 P.2d 91, 94–95 (Okla. Civ. App. 1976)). In Oklahoma, “circumstantial evidence may be used to support the probability of a defect,” and “it is not necessary that such proof rise to such degree of certainty as to support only one reasonable conclusion and exclude all others.” Dutsch, 845 P.2d at 190–91 (quoting Kirkland, 521 P.2d at 1364).

In particular, the Oklahoma Supreme Court has permitted cases to proceed where the “testimony of [a] plaintiff’s expert outlined design defects in” the product “and concluded that these defects hid and enhanced [the] deterioration of the” product, later causing the injury. Blood v. R & R Eng’g, Inc., 769 P.2d 144, 145 (Okla. 1989). As in Hurd, Dr. Anderson’s testimony here is “that the age of the product did not have a bearing on the kind of failure that took place,” and that “the problem” was “the manner in which” the disc “wore out.” 734 F.3d at 501. This is sufficient evidence to raise a genuine

dispute of material fact.

Bosch additionally contends that “evidence of a product defect” is “lacking in this case” because Mr. AlNahas has not “presented evidence of a design used by other manufacturers,” or some other “alternative design.” Aple. Br. at 16. Applying Oklahoma law, we have repeatedly rejected this exact argument. “While evidence bearing upon design alternatives and the ‘state of the art’ in the industry may be relevant to determining whether a product is unreasonably dangerous, such evidence is not an essential element of the plaintiff’s case.” Karns v. Emerson Elec. Co., 817 F.2d 1452, 1457 (10th Cir. 1987) (quotation marks and citations omitted) (applying Oklahoma law).

Finally, Bosch claims that Mr. “AlNahas’s injury was not caused by any condition that existed on the [disc] or the sander when Bosch sold it.” Aple. Br. at 18. The only distinct argument on this element that we can discern from this portion of the brief is that Dr. Anderson “conceded that the sander was appropriate for its purposes at the time it left Bosch’s control.” Id. at 16. Bosch grossly mischaracterizes Dr. Anderson’s testimony. As discussed, he testified that when the sander left Bosch’s control, all of these defects existed, and lay hidden in the disc until the day of the accident.

We conclude that there are genuine disputes of material fact regarding whether the alleged defect existed when the sander and its disc left Bosch’s control.

iii. Unreasonable dangerousness



Mr. AlNahas contends that Bosch “knew or should have known that the materials” it used for the disc “would, over time, degrade and fracture[,] and could become deadly projectiles.” Aplt. Br. at 35. Thus, he argues that the sander was an unreasonably dangerous product because the “end-of-life characteristics” of the disc “are dangerous and not readily appreciated by users of the product.” Id. at 13.

The district court concluded that Mr. AlNahas “failed to present sufficient evidence to raise a triable issue of fact as to whether the sander was dangerous beyond the extent contemplated by an ordinary consumer.” Aplt. App. at 266. We are unable to discern the rationale for this determination. In any event, we disagree.

Under Oklahoma law, a “design must be as safe as the best available testing and research permits.” Tansy v. Dacomed Corp., 890 P.2d 881, 885 (Okla. 1994) (quotation marks and citation omitted). “There must be at the time of manufacture and distribution no feasible alternative design which on balance accomplished the subject product’s purpose with a lesser risk.” Id. (quotation marks and citation omitted). “The manufacturers of the product are held to the knowledge and experience of experts in their fields.” Id. at 885–86. We therefore cannot agree with the district court’s unsupported declaration that the sander was not unreasonably dangerous as a matter of law. After all, the disc fractured, which is not its normal operation, and it injured Mr. AlNahas. See Braswell, 731 F.3d at 1086–88 (discussing products that cause injuries while behaving as

intended). While the district court may ultimately be correct in its view, the court's ruling as presented is unsupported.

That said, of course, “merely because a product could be made ‘safer’ does not mean it posed an unreasonable danger to the ordinary consumer who used it.” Id. at 1087. “Only when a defect in the product renders it less safe than expected by the ordinary consumer will the manufacturer be held responsible.” Gaines-Tabb v. ICI Explosives, USA, Inc., 160 F.3d 613, 624–25 (10th Cir. 1998) (quoting Lamke v. Futorian Corp., 709 P.2d 684, 686 (Okla. 1985)). More specifically, “[u]nder Oklahoma law, a product is unreasonably dangerous if it poses a danger ‘beyond that which would be contemplated by the ordinary consumer who purchases it, with the ordinary knowledge common to the community as to its characteristics.’” Braswell, 731 F.3d at 1087 (quoting Woods v. Fruehauf Trailer Corp., 765 P.2d 770, 774 (Okla. 1988)).

“The ‘ordinary consumer’ is ‘one who would be foreseeably expected to purchase the product involved.’” Gaines-Tabb, 160 F.3d at 624 (quoting Woods, 765 P.2d at 774). Whether a product is unreasonably dangerous beyond the expectations of an ordinary consumer is “an objective test.” Braswell, 731 F.3d at 1089. Consequently, the district court erred when it summarily concluded that an ordinary purchaser of a random-orbit sander would expect to be at risk of injury from the disc fracturing, or to be at risk of sustaining injury from flying debris during a test of whether the sander powers on.

For its part, Bosch addresses this element by first claiming that Dr. “Anderson’s design criticisms, even if they were valid and reliable, still are not evidence.” Aple. Br. at 16. But they are. See, e.g., Fed. R. Civ. P. 702; Etherton, 829 F.3d at 1216.

Next, Bosch claims that Mr. AlNahhas and Dr. Anderson both “proved” that “[t]he sander, as designed, did not pose a danger beyond the expectations of an ordinary consumer of the sander.” Aple. Br. at 17–18. In particular, Bosch claims that Dr. “Anderson testified that common sense should have told [Mr.] AlNahhas that turning on the sander while pointing the disc at his face was dangerous.” Id. at 18. Again, we have no record support for this statement.

Finally, Bosch states it is entitled to summary judgment because Mr. “AlNahhas was aware of *the* danger; he testified that he always wore goggles and other safety equipment when he *performed* *woodwork*.” Id. (emphasis added). Bosch does not expound on this argument. Elsewhere in its brief, however, it claims that “the danger of an eye injury while using a rapidly rotating sander is well within the expectations of the ordinary user of a sander, and was known to [Mr.] AlNahhas.” Id. at 11. We disagree.

We have recognized that a plaintiff may succeed in proving “that [a] product was unreasonably dangerous” under Oklahoma law where it “is dangerous because the manner in which it wears makes it prone to sudden and unexpected collapse.” Hurd, 734 F.2d at 500 n.5; see also Lamke, 709 P.2d at 686 (comparing the known risk of a type of injury to the allegedly unknown, but increased risk of that injury occurring). Where an

expert witness testifies to this, we have found it “sufficient to establish that the product was unreasonably dangerous under Oklahoma law.” Hurd, 734 F.3d at 500 n.5.

The same is true here. Again, it is a genuine dispute of fact whether Mr. AlNahhas was “using” the sander at the time he powered it on and conducted his test. But regardless of how Mr. AlNahhas’s actions are properly characterized, it would not warrant granting summary judgment to Bosch. Mr. AlNahhas argues that an ordinary purchaser of the sander would be “completely unaware he was operating [a] sander that contained a defective [disc,] or that such a [disc] posed a danger.” Aplt. Br. at 28–29. Indeed, he testified that he did not expect the disc to fracture, or to be at risk of any injury from flying debris while he merely tested whether the sander would power on.

Dr. Anderson also testified to that effect, providing context and details that we will not repeat but which plainly foreclose summary judgment resolution of the issue in Bosch’s favor. See Aplt. App. at 155–64. Bosch does not offer any argument to the contrary—it wholly fails to address whether an ordinary purchaser of a random-orbit sander would expect the rotating disc to behave in this manner, or would appreciate the risk thereof. Moreover, though Bosch contends that Mr. AlNahhas should have appreciated certain risks of injury while *using* the sander, this does not establish that, as a matter of law, the *owner* of the sander would expect to sustain any injury from flying debris while merely *testing the sander*.

We conclude that whether the sander was unreasonably dangerous is a genuine

dispute of material fact. In sum, and to the extent that this is a separate claim for relief, see Braswell, 731 F.3d at 1092 n.3, we conclude that genuine disputes of material fact remain on the prima facie elements of Mr. AlNahhas's claim of design defect.

b. Failure to warn

We now turn to Mr. AlNahhas's claim that Bosch failed to warn him that the disc could fracture and relatedly failed to provide him with any warning about the risks of injury that he faced from such an occurrence. These are the only statements in the manual that specifically refer to the disc: "After considerable service[,] the [disc] surface will become worn, and the [disc] must be replaced when it no longer offers a firm grip. If you are experiencing premature wear[-]out of the [disc] facing, decrease the amount of pressure you are applying during operation of the tool." Aplt. App. at 117.

Conspicuously absent from these statements is any warning that the disc might fracture, or of the risk that the disc would pose to an ordinary consumer of the sander if it did.

"Oklahoma's products liability law 'generally requires a manufacturer to warn consumers of danger associated with the use of its product to the extent the manufacturer knew or should have known of the danger.'" Eck v. Parke, Davis & Co., 256 F.3d 1013, 1017 (10th Cir. 2001) (quoting Edwards v. Basel Pharms., 933 P.2d 298, 300 (Okla. 1997)). "Even if a product is faultlessly designed and the manufacturer has exercised all possible care in the preparation and sale of his product, it may be considered unreasonably unsafe or defective if it is placed in the hands of the ultimate consumer

without adequate warnings of the dangers involved in its use.” McKee v. Moore, 648 P.2d 21, 23 (Okla. 1982) (footnote omitted). On the other hand, “[e]ven where a product’s design defect makes the product unreasonably dangerous, Oklahoma law does not impose liability if the product contains a warning that adequately addresses the known risks of use.” Braswell, 731 F.3d at 1087 (quotation marks and citations omitted). “To recover in a failure to warn case, a plaintiff must establish both cause-in-fact (that the product in question caused the injury) and proximate cause (that the manufacturer of the product ‘breached a duty to warn of possible detrimental [effects]’).” Eck, 256 F.3d at 1017 (quoting McKee, 648 P.2d at 23–24).

i. Cause-in-fact

We have already discussed direct causation in the context of Mr. AlNahhas’s design defect claim. We will not repeat that analysis. It suffices to say that a direct cause of Mr. AlNahhas’s injury was that the disc fractured and pieces of it flew into his eye.

ii. Proximate cause

“To qualify as a proximate cause of the injury, the breach of a duty or failure to warn must be a substantial contributing factor in bringing about the harm in question.” Id. Thus, we must first address whether Bosch had such a duty, and then whether the failure to fulfill it substantially contributed to Mr. AlNahhas’s injury.

Our first inquiry is whether the “warnings on” the product “covered all the salient

dangers accompanying its operation.” Braswell, 731 F.3d at 1089 (citation omitted).

More specifically, the Oklahoma Supreme Court has enunciated the following standard:

If a product is potentially dangerous to consumers, a manufacturer is required to give directions or warnings . . . as to its use. If these warnings cover all foreseeable use and if the product is not unreasonably dangerous if the warnings and directions are followed, the product is not defective in this respect. If the warnings are unclear or inadequate to apprise the consumer of the inherent or latent danger, the product may be defective; particularly where a manufacturer has reason to anticipate danger may result from the use of [the] product and the product fails to contain adequate warning of such danger, the product is sold in a defective condition.

McPhail v. Deere & Co., 529 F.3d 947, 957–58 (10th Cir. 2008) (quoting Smith v. U.S. Gypsum Co., 612 P.2d 251, 253–54 (Okla. 1980)); see Smith, 612 P.2d at 253–54 (explaining that “[f]oreseeability as used” in this context “is not to be confused with foreseeability involved in the concept of proximate cause under a negligence theory”).

On the other hand, “Oklahoma does not recognize a duty to warn of dangers that are obvious.” Ahrens v. Ford Motor Co., 340 F.3d 1142, 1146–47 (10th Cir. 2003). Obvious dangers are those that “are open and easily discernable.” Grover v. Superior Welding, Inc., 893 P.2d 500, 503–04 (Okla. 1995). There is also “no duty to warn a knowledgeable user of the product of the dangers associated therewith.” Braswell, 731 F.3d at 1090 (quoting Duane v. Okla. Gas & Elec. Co., 833 P.2d 284, 286 (Okla. 1992)). Oklahoma law therefore does not require “warning of the dangers involved in using the” product that “would not have informed the” injured person “of anything he did not already know.” Grover, 893 P.2d at 503.

Finally, however, a “manufacturer cannot defend on the basis that perfect compliance with its instructions would have prevented the accident when the warnings given are *unclear or inadequate* to apprise the consumer of the inherent or latent danger.” Karns, 817 F.2d at 1457–58 (emphasis added) (quotation marks and citation omitted). We view such “cautionary phrases, taken in the light most favorable to the party opposing summary judgment,” to determine whether they “give rise to an issue of fact regarding the clarity and adequacy of [a] warning.” McPhail, 529 F.3d at 959.

Mr. AlNahas argues that no warning on the sander or in the manual informed him of the unknown danger that the disc could fracture and injure him. As we alluded to at the outset, it was in analyzing this claim that the district court relied exclusively on out-of-state authorities, and granted summary judgment to Bosch. That was an erroneous approach in these circumstances. Cf., e.g., Bingham v. Hollingsworth Mfg. Co., 695 F.2d 445, 449 (10th Cir. 1982) (discussing Oklahoma cases with facts similar to those described in the cases the district court relied on, and reaching the opposite result).

In any event, we disagree with the conclusion that “the sander’s general caution to ‘always wear eye protection’ and other warnings were unambiguous and adequately advised [Mr.] AlNahas of the danger of the very injury of which he now complains.” Aplt. App. at 270. In particular, we question the conclusion that: “*The warnings were simple, straightforward, and correlated to implicit but unexpressed dangers; they need not have warned a user to always wear eye protection to prevent injury from the specific*



occurrence of a broken sanding disc.” Id. at 271 (first three emphases added, last emphasis in original).

We are unable to discern which “warnings” are referred to or to which “implicit but unexpressed dangers” those warnings were “correlated.” Id. Though several statements found on the sander and in the manual are discussed in the district court’s order, none of those statements warn of the risk that the disc could fracture. Nor do those statements warn that a person might suffer an injury—to the eye, or otherwise—from such an occurrence. See McPhail, 529 F.3d at 960 (denying summary judgment where “the evidence in the record regarding [the plaintiff’s] knowledge relate[d] to the dangers of [using the device] generally, and not to the specific dangerousness at issue [t]here”). Under the circumstances, we cannot agree with the district court’s conclusion that this is enough to then conclude that the “warnings on the sander and those found in the manual were adequate” as a matter of law. Aplt. App. at 271.

In particular, we perceive nothing obvious about the risk that the disc could fracture, at least not that would permit us to conclude this as a matter of law. See Ahrens, 340 F.3d at 1146–47; Grover, 893 P.2d at 503–04. Indeed, Mr. AlNahas testified that he was unaware of these risks. There is no statement on the sander or in the manual from which we could conclude that, contrary to his testimony, he knew of these risks. See Braswell, 731 F.3d at 1090. We conclude that genuine disputes of material fact remain regarding whether an additional warning would have informed Mr. AlNahas of these

risks, which are risks that he “did not already know” about. Grover, 893 P.2d at 503.

Bosch adopts a similar approach. It discusses “warnings and instructions,” but it does not explain precisely which statements on the warning label affixed to the sander or in the manual actually address the risk that the disc could fracture. Aple. Br. at 2. For example, Bosch does not direct us to any statement that allegedly addresses the types of circumstances in which the disc may fracture, how the owner is to discern if or when this is likely to occur, or what precautions the owner should take to minimize the risk. See Braswell, 731 F.3d at 1090 (discussing “lingering *unknown* danger[s]”). The instruction in the manual that “the [disc] must be replaced when it no longer offers a firm grip,” Aplt. App. at 117, does not appear to clearly *or* adequately address these questions, let alone clearly *and* adequately do so, as Oklahoma law requires. See McPhail, 529 F.3d at 957–58; Karns, 817 F.2d at 1457–58.

Bosch’s argument that the disc “is a wear item that needs to be replaced during the useful life of the sander” is irrelevant to whether Bosch failed to warn of these particular risks. Aple. Br. at 2. The same is true of Bosch’s claim that it “was not required to provide yet an additional warning that the sanding pad—a wear item—might break at the end of its useful life,” the ultimate issue in dispute. Id. at 12. Indeed, Dr. Anderson testified that “something” should inform the owner that it is “time to replace” the disc, in similar fashion to the treads on a “tire.” Aplt. App. at 170 (“[W]hen you have a good design, . . . you see something that comes up that tells you it’s time to replace” it, “like on

tires. . . . Most end-of-life equipment has that, some fiber or something that is going to tell you that. It certainly could have been added to this disc to give you a health check on it. It wasn't."). Moreover, no evidence shows that Mr. AlNahas's disc could no longer firmly grip sandpaper, the only statement in the manual indicating when the disc is "at the end of its useful life." Aple. Br. at 12.

Bosch also claims that the warnings adequately cover this occurrence because Mr. "AlNahas would never have been injured if he had simply followed the warnings to always wear eye protection." Id. But as discussed, it is a genuine dispute of fact whether the statements on the sander or in the manual would have indicated to a reasonable owner that he was required to wear eye protection *even while not sanding*, a dispute which is material as to this claim. See, e.g., Wheeler v. HO Sports Inc., 232 F.3d 754, 759 (10th Cir. 2000) ("The warning did not alert Mr. Wheeler that he would not float at all, and sinking poses a distinctly different danger than not floating in a certain manner. . . . A jury may agree with the district court that these general statements trump the specific warnings we have discussed, but that decision is one for the jury to make.").

There are genuine disputes of material fact regarding whether Bosch breached a duty to warn Mr. AlNahas of these risks. See Eck, 256 F.3d at 1017.

We must now address whether the alleged breach of that duty was a "substantial contributing factor in bringing about" Mr. AlNahas's injury. Id. Bosch claims there is "evidence that [Mr.] AlNahas disregarded the warnings and instructions that were

provided,” so any added warning “would not have changed the outcome in this case.” Aple. Br. at 12. The district court similarly found that he “has not presented any sufficient evidence indicating that he would have heeded and followed a more adequate warning,” because, “in his view, he was not ‘using’ the sander when the accident occurred.” Aplt. App. at 271. We disagree on both scores.

Specifically, “[u]nder Oklahoma law, there is a rebuttable presumption that” a plaintiff “would have read and heeded an adequate warning.” Black, 269 F.3d at 1231–32. “Thus, in the absence of evidence rebutting the presumption, a plaintiff need not produce evidence that she [or he] would have acted differently if an adequate warning had been given.” Daniel v. Ben E. Keith Co., 97 F.3d 1329, 1332 (10th Cir. 1996). “This presumption, however, disappears once the defendant comes forward with some evidence indicating that the plaintiff would not have followed the warning.” Black, 269 F.3d at 1231–32.

As Bosch notes, Mr. AlNahas “testified that he always wore eye protection when he performed woodwork.” Aple. Br. at 11. Bosch has not shown that he failed to follow those instructions in any circumstance where it was *clear* that the warnings applied. There is also no evidence that Mr. AlNahas failed to replace the disc as instructed, because the record is silent about whether it could still firmly grip sandpaper. These are the only two instructions that Mr. AlNahas is accused of failing to heed, but he followed them both. Therefore, Bosch has not rebutted the presumption that Mr. AlNahas would

have heeded any additional warnings that it provided. See Black, 269 F.3d at 1231–32.

We conclude that this heeding presumption applies in Mr. AlNahhas’s case.

In sum, we conclude that genuine disputes of material fact preclude summary judgment on the prima facie elements of Mr. AlNahhas’s failure to warn claim.

c. Bosch’s affirmative defenses

The final issue that we must address is Bosch’s apparent claim to be entitled to summary judgment based on affirmative defenses. Specifically, the “two defenses to manufacturer’s products liability” potentially applicable here are “abnormal use and voluntary assumption of the risk of a known defect,” which “are affirmative defenses and must be pled or they are waived.” Treadway v. Uniroyal Tire Co., 766 P.2d 938, 941 (Okla. 1988). “The defense of contributory negligence is not available.” Id.

To the extent that Bosch might be asserting an affirmative defense that Mr. AlNahhas voluntarily assumed a *known* risk, Bosch does not specifically describe that defense in its brief, let alone explain how it would apply here. See Holt v. Deere & Co., 24 F.3d 1289, 1292 (10th Cir. 1994) (“A manufacturer may allege as an affirmative defense the plaintiff’s ‘voluntary assumption of or exposure to the risk of a known defect.’” (quoting Thomas v. Holliday, 764 P.2d 165, 167 n.5 (Okla. 1988))). Where reasonable minds “might differ on the question of whether [a] plaintiff’s awareness of [a specific] defect and continued use of the [product] was [the] proximate cause of the [injury], this defense is a question of fact for the jury.” Bingham, 695 F.2d at 450. In any

event, Bosch failed to brief this defense adequately, waiving our further consideration of it here. See De Vaughn, 694 F.3d at 1154–55.

Bosch does note, on the other hand, that it pled an “affirmative defense” that the “sander was not being used as reasonably anticipated when the accident occurred.” Aple. Br. at 9. It also devotes some attention to arguing that the sander was “worn,” and suggests that Mr. AlNahhas “abuse[d]” or “misused the sander.” Id. at 18. The district court did not discuss this affirmative defense, though it mentioned certain facts that are relevant, if at all, only to that defense. E.g., Aplt. App. at 265 (discussing Dr. Anderson’s testimony about how much he thought the sander had been “used”).

Yet Bosch does not discuss its burden to plead and prove this defense, or discuss the specifics of how any of this evidence could establish that defense, let alone as a matter of law. See Treadway, 766 P.2d at 941 (“Abnormal use or misuse of a product occurs where the method of using a product is not that which the maker intended or is a use that could not reasonably be anticipated by a manufacturer. . . . [A] distinction must be drawn between use for an abnormal purpose and *use for a proper purpose but in a careless manner*. The latter use would properly be described as contributory negligence, which is *not a defense* to manufacturer’s products liability cases.” (emphasis added)); see Black, 269 F.3d at 1234 (same). We cannot affirm the grant of summary judgment based on this inadequately supported defense. See De Vaughn, 694 F.3d at 1154–55.

E. Conclusion

We conclude that the district court erred when it granted summary judgment to Bosch on Mr. AlNahas's claims of design defect and failure to warn. Genuine disputes of material fact remain on both claims, which necessitates our remand for further proceedings.

**III.**

We AFFIRM the district court's grant of summary judgment to "Skil Tools," a nonexistent entity, on all claims.

We REVERSE the district court's order granting summary judgment to Bosch on Mrs. AlNahas's loss of consortium claim and Mr. AlNahas's claims of design defect and failure to warn. We REMAND those claims for further proceedings consistent with this opinion.

Entered for the Court

Mary Beck Briscoe  
Circuit Judge

## Appendix

Four images from the record follow. The first image is of the warning label affixed to the side of the sander. Aplt. App. at 140.

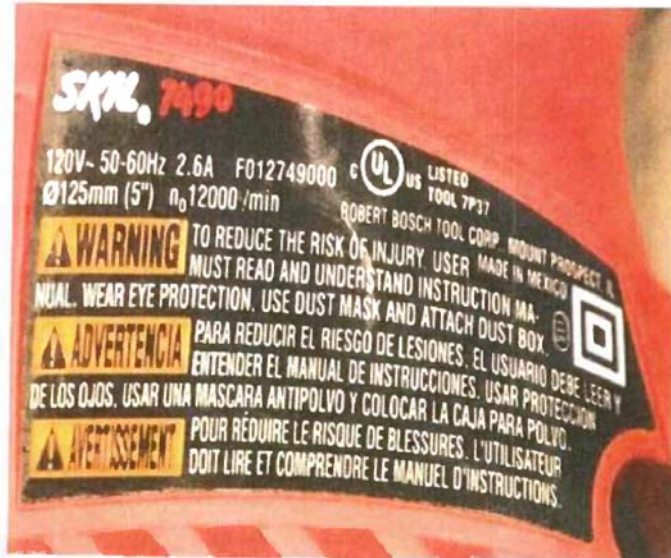

This picture shows a side view of Mr. AlNahas's sander and its assembly, and shows a top-down view of the inward-facing sides of the fractured disc. Id. at 193.





This picture is of the outward-facing sides of the fractured disc. Id. at 194.



The last image is a diagram of the sander that appears in the manual; it depicts a piece of sandpaper (the “abrasive disc”) and the disc (the “backing pad”), though not the assembly, which is covered by the disc. Id. at 116.

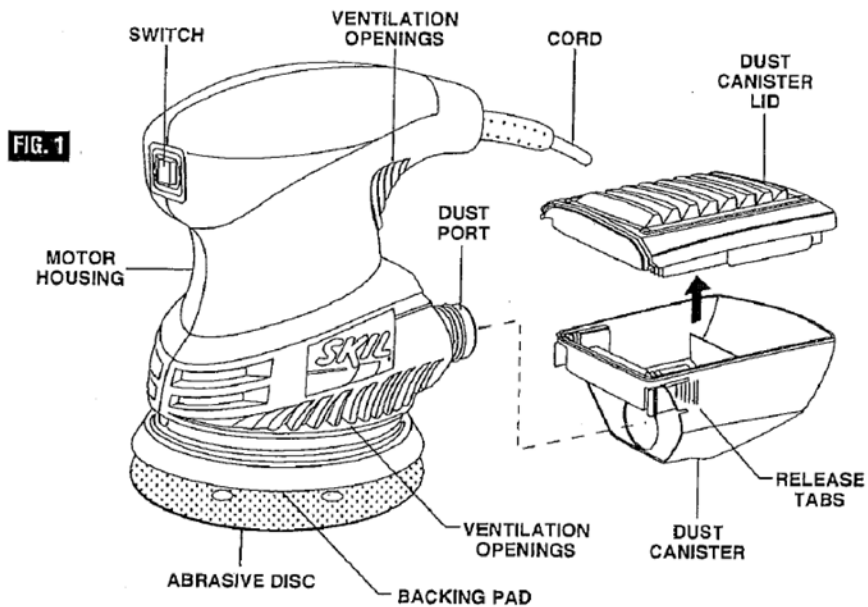

16-6163, *AlNahhas v. Bosch, et al.*

**MURPHY, J.**, concurring and concurring in the judgment.

This court will reverse the district court's grant of summary judgment in favor of Bosch if Mr. AlNahhas is able to identify facts sufficient to establish "an inference of the presence of each element essential to the case." *Savant Homes, Inc. v. Collins*, 809 F.3d 1133, 1138 (10th Cir. 2016) (quotation omitted). As to Mr. AlNahhas's design defect claim, the relevant evidence is so scant I perceive only one sliver that justifies reversal: Dr. Anderson's testimony the disc was defectively designed because, when it reached the end of its useful life, it failed "ballistically" instead of "benignly." Although Dr. Anderson did not offer an alternative design or opine that one is even feasible, such evidence is not necessary. Majority Op. at 30.

Most of Dr. Anderson's other testimony is less than clear on the design defect issue. To use the Majority's example, Bosch asserts Dr. Anderson acknowledged Mr. AlNahhas was not injured by the separation of the foam from the insertion plate even though he identified separation as the design defect. Majority Op. at 8. The Majority labels this assertion a "distortion" of the evidence, supporting its characterization with an excerpt from Dr. Anderson's deposition testimony. *Id.* In that testimony, however, Dr. Anderson discusses fracture, not separation. *Id.* True, Dr. Anderson later testified that material separation can cause the disc to fracture. But he also testified, consistent with

Bosch's argument, that he saw "no separation from the foam and the plastic insertion plate" in Mr. AlNahhas's case.

Rather than illustrating a distortion of the evidence by Bosch, this example exposes the confusing and conflicting nature of Dr. Anderson's testimony. It also calls into question the relevance of Dr. Anderson's lengthy testimony about material separation. The issues surrounding Dr. Anderson's testimony and report are best left to the district court to resolve in the first instance by conducting a *Daubert* analysis or otherwise addressing Bosch's challenges. *See Daubert v. Merrell Dow Pharm., Inc.*, 509 U.S. 579, 592 (1993) (describing a district court's gatekeeping function with respect to expert scientific testimony).

Because I do not fully agree with the Majority's analysis of the design defect claim, as to that claim I concur in the judgment only.